

4.5V-60V Vin, 0.6A, High Efficiency Step-down DCDC Converter

FEATURES

-
-

-
-
-
-
-
-
-
-
-
-
-
-
-
-
-

APPLICATIONS

-
-
-

REVISION HISTORY

DEVICE ORDER INFORMATION

RECOMMENDED OPERATING CONDITIONS

ESD RATINGS

- (1)
- (2)

THERMAL INFORMATION

D Q2S

D

Q

ELECTRICAL CHARACTERISTICS

TYPICAL CHARACTERISTICS

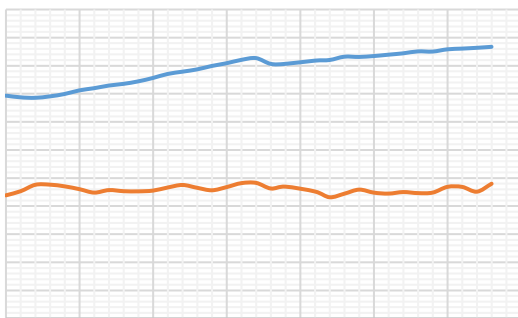
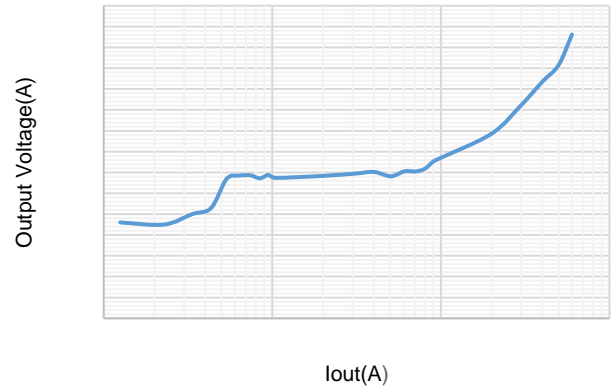
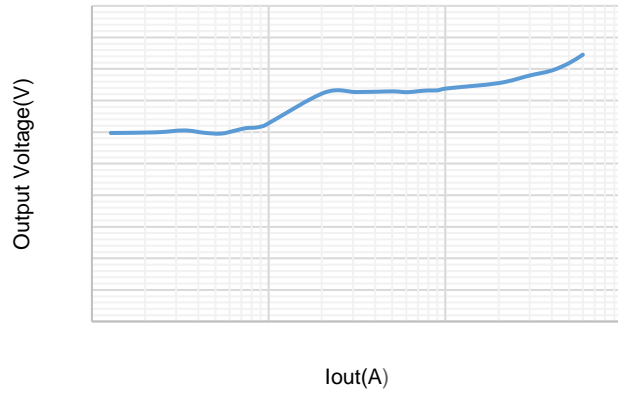
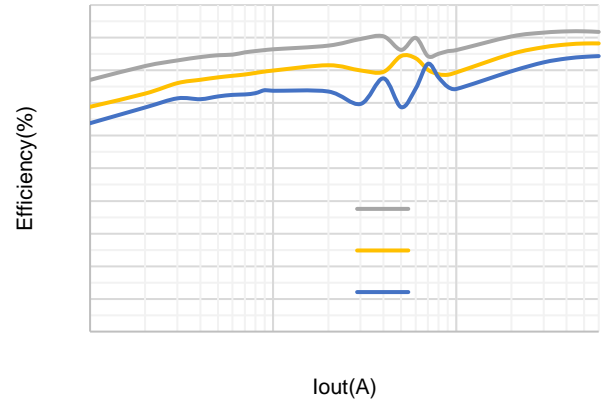
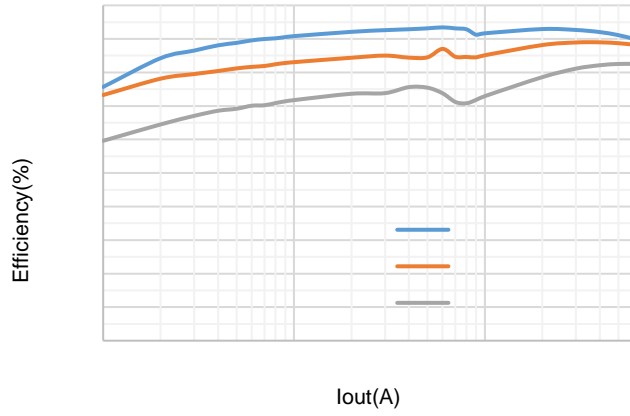

FUNCTIONAL BLOCK DIAGRAM

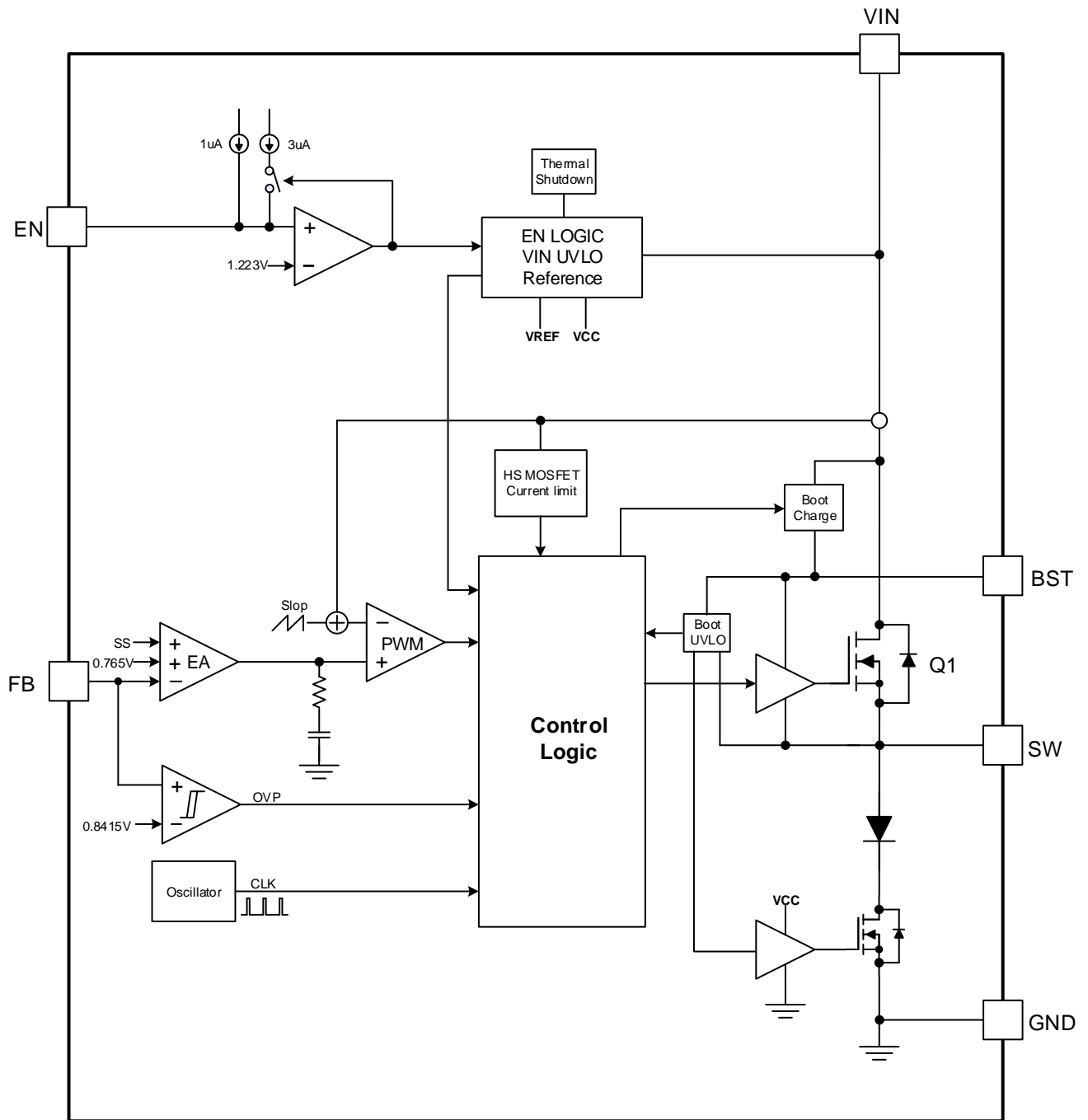

OPERATION

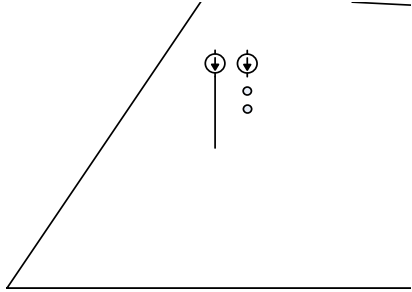

-
-

±2.5



-
-





—

•





-
-
-
-
-
-



-
- -
 -
 -
 -
 -

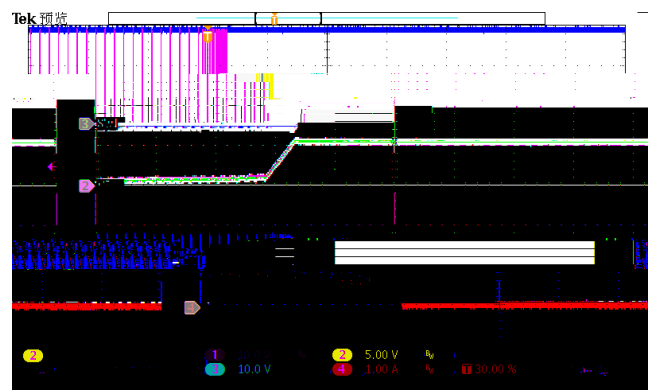
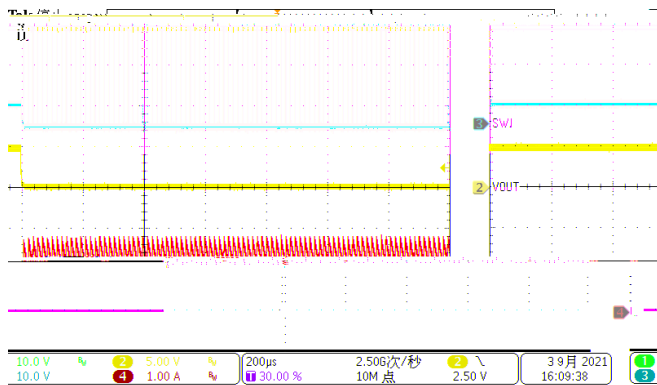
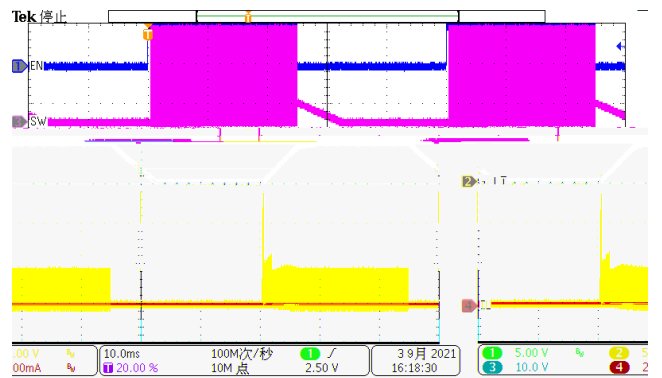
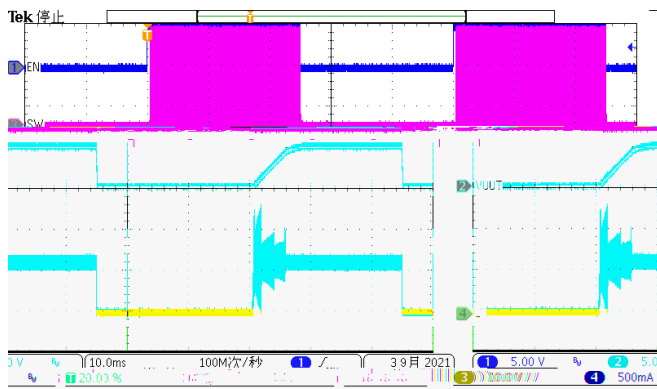
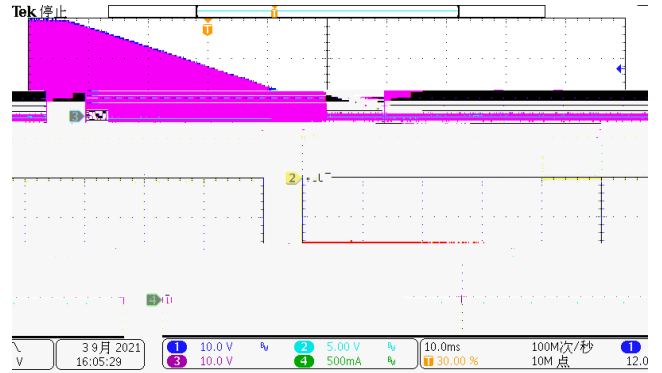
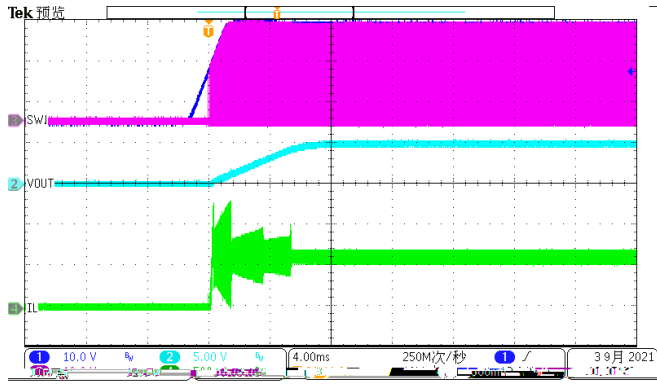

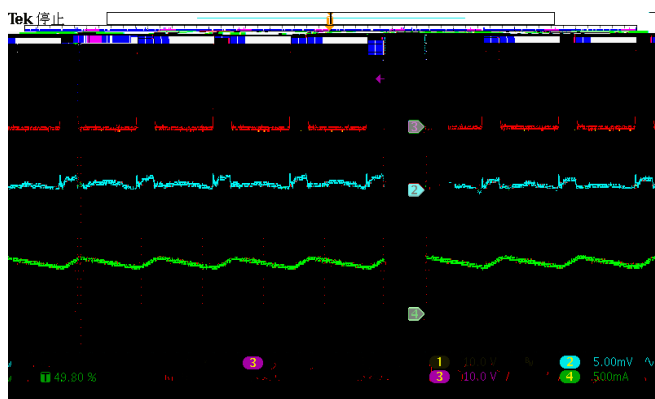
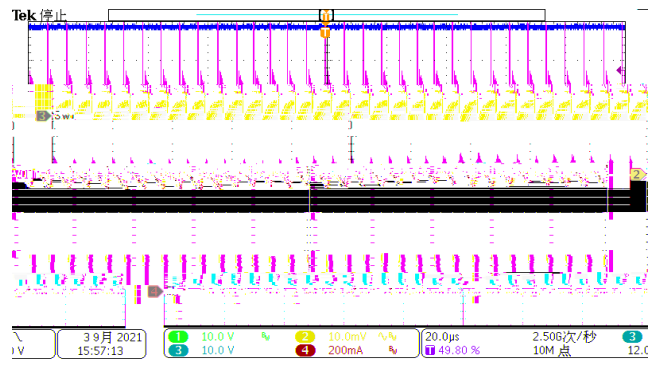
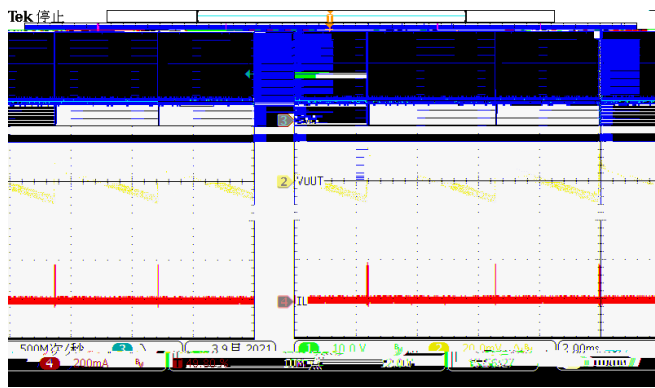
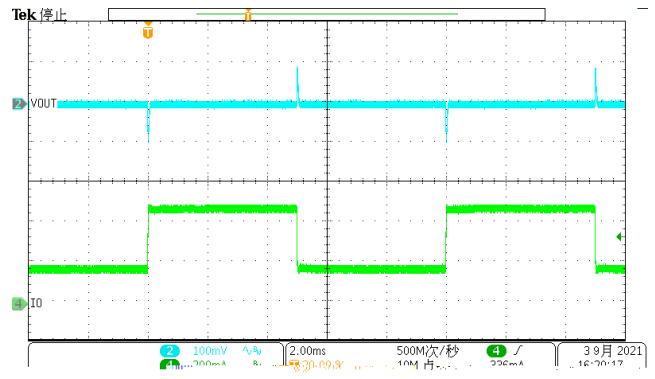
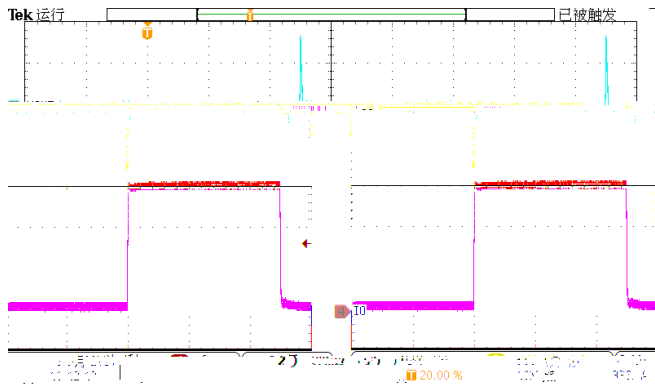

- 1.
- 2.
- 3.
- 4.
- 5.
- 6.

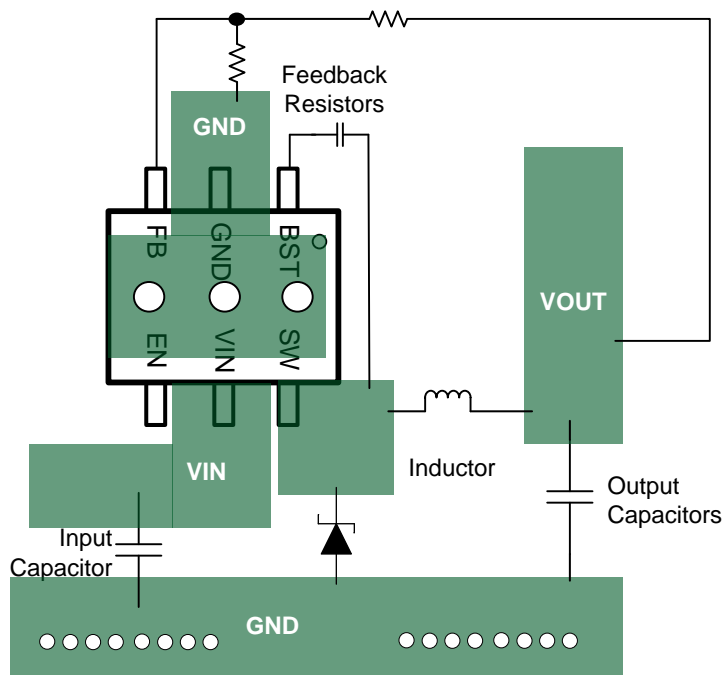

•
•

PACKAGE INFORMATION

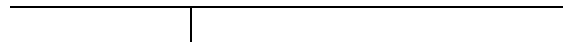
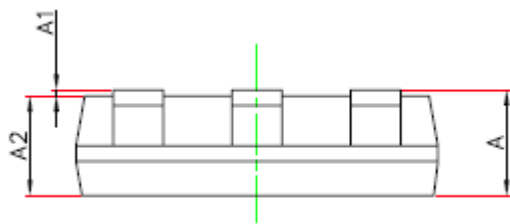
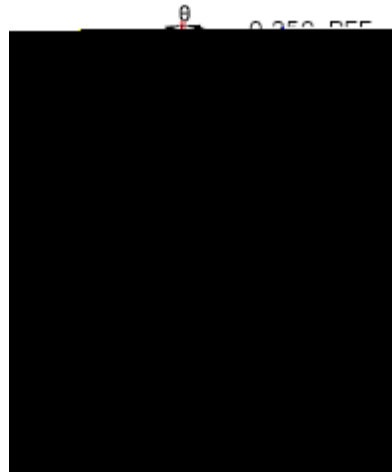
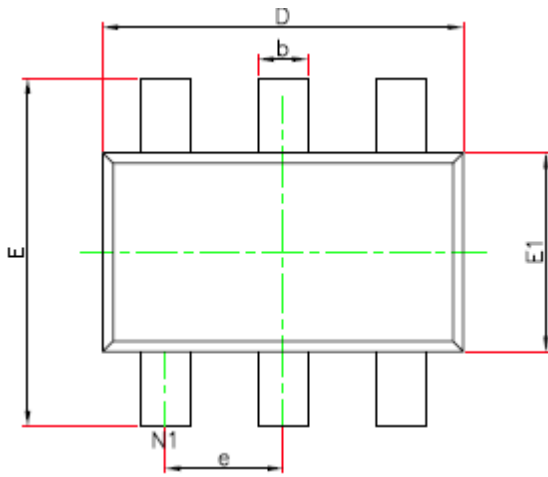

- 1.
- 2.
- 3.
- 4.
- 5.
- 6.

TAPE AND REEL INFORMATION

